

## PORTALAUSTRÄUMER

**ANWENDUNG:**  
Ausräumen von Stanzteilen

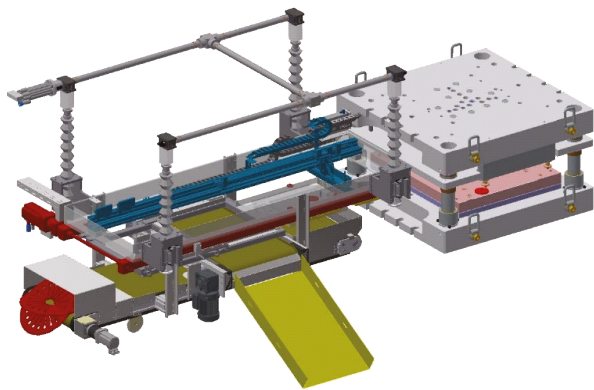
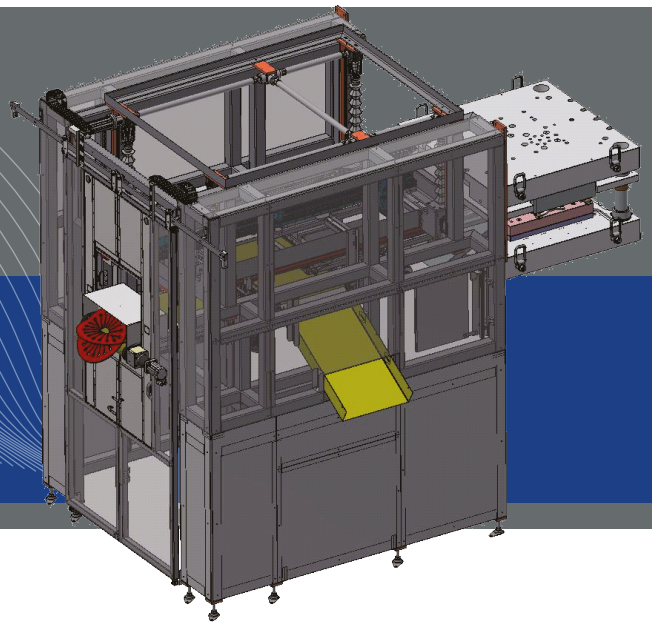

## PROZESSABLAUF

1. Stanzteil liegt im geöffnetem Werkzeug
2. Formgreifer fährt in geöffnetes Werkzeug
3. Greifen der Stanzteile mittels Elektromagnet
4. Formgreifer fährt mit Teilen aus Stanzwerkzeug heraus
5. Sortierung Stanzteile und Abfall außerhalb Werkzeug



## VORTEILE

- o Schnelles reproduzierbares Ausräumen von Stanzteilen
- o Kurze Taktzeit
- o Kurze Rüstvorgänge
- o Typspezifischer Wechselgreifer durch RFID-Codierung
- o Automatische typspezifische Positionsanpassung

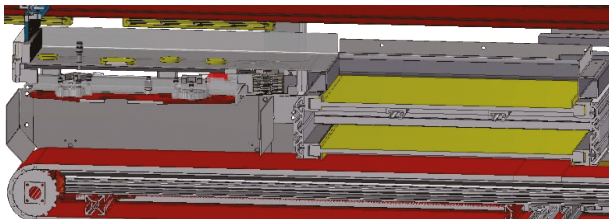

## PORTAL HANDLING SYSTEM

**APPLICATION:**  
removal of stamped parts

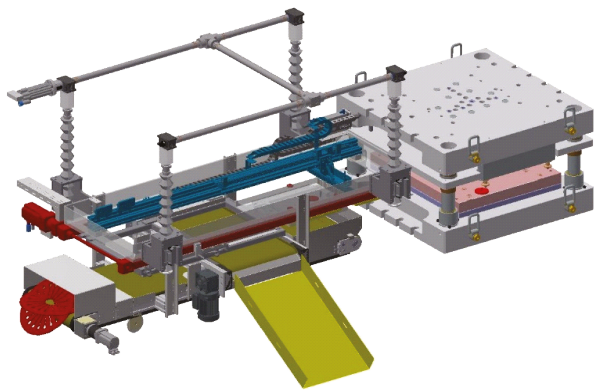
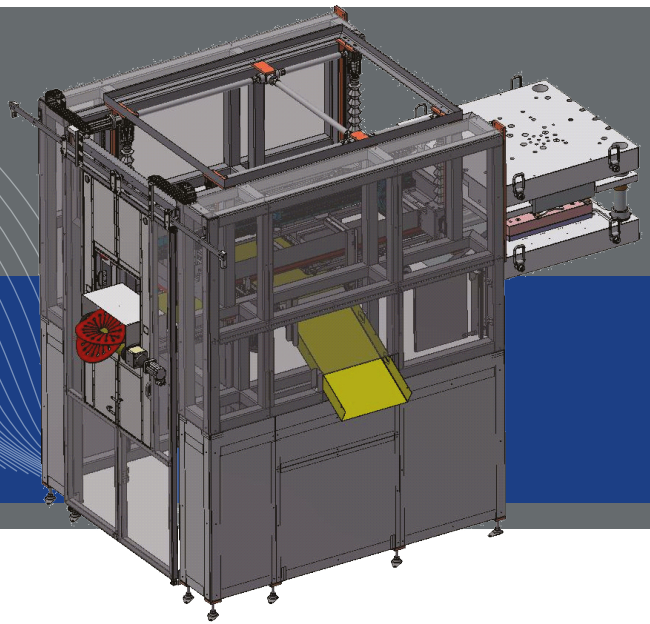

### PROCESS PROCEDURE

1. Stamping lies in the open tool
2. Form gripper moves into the open tool
3. Gripping of the stamped parts by means of electromagnet
4. Form gripper moves out of punching tool with parts
5. Sorting stamped parts and waste outside the tool

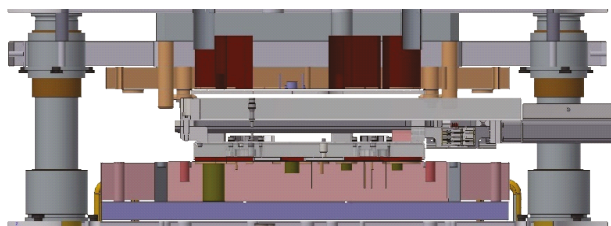

### BENEFITS

- o Fast reproducible remove of stamped parts
- o Short cycle time
- o Short set-up times
- o Change of gripper for each type through RFID-coding
- o Adjustment of type-specific position automatically

